

Bonnet Lifter installation instructions:

VW Mk1 Golf, Caddy 1, Jetta 1

- Please read full instructions before installation
- If the cylinder is under pressure, please do not open or heat up
- Lifting force will be lower in colder temperatures
- Always install the cylinder facing upwards

Included in Kit:

2 x Bonnet lifter
4 x right angled-joint & security clip
4 x M6 x 20mm ball pins
4 x M6 large washer
2 x M6 small washer
2 x M6 Nut

Tools Required

10mm ring spanner
4mm and 6mm drill

Fitting Instructions

1. Remove the front M6 bolts from the left hinge (A).
2. Fit the supplied M6 x 20mm ballpin plus washers.
3. Drill a 6mm hole into the wing for the fitting of the bonnet lifter, with a 335mm distance to the bonnet hinge (B). Attention: this hole needs to be 20mm distance to the edge of the bonnet.
4. Apply an anti rust/corrosion to the drilled hole and fit the ballpin with the large washer at the top and the small nut and washer at the bottom of the wing. (some models will require for the inner wing to be removed before the fitting)
5. Fit the joints to the Bonnet lifter and remove the security clips.
6. Fit the Bonnet lifter (cylinder facing upwards) to the ballpin (make sure they are fitted tightly).
7. Fit the security pin back to the joint, these are needed for the bonnet lifter to continue working.
8. Repeat the same installation process for the other side.

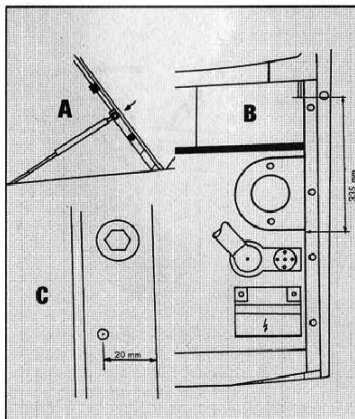

VW Mk2 Golf, Jetta 1

- Please read full instructions before installation
- If the cylinder is under pressure, please do not open or heat up
- Lifting force will be lower in colder temperatures
- Always install the cylinder facing upwards

Included in Kit:

2 x Bonnet lifter
4 x right angled-joint & security clip
4 x M6 x 20mm ball pins
2 x ballscrew
2 x M6 large washer
2 x M6 toothed washer
2 x M6 Nut

Tools Required

10mm ring spanner & 10mm socket spanner
4mm and 6.5mm drill

Fitting Instructions

1. Remove the front M6 bolts from the left hinge (A).
2. Drill a 6.5mm hole into the wing for the fitting of the bonnet lifter, with a distance of 25mm to the front hole and 13mm distance to the bonnet. (A)
3. Apply an anti rust/corrosion to the drilled hole and remove the rubber plug (next to the hinge) from the bonnet.
4. Remove all of the metal dust from the bonnet.
5. Fit the M6 x 20mm ballpin with the small washer at the bottom and the toothed washer at the top of the wing and screw on the ballscrew.
6. Unwind the front M6 Bolt.
7. Remove the second (from the front) chassi bolt.
8. In its place fit the ballpin, using the washer.
9. Remove the foam block which is glued to the hinge.
10. Fit the joints to the Bonnet lifter and remove the security clips.
11. Fit the Bonnet lifter (cylinder facing upwards) to the ballpin (make sure they are fitted tightly).
12. Fit the security pin back to the joint, these are needed for the bonnet lifter to continue working.
13. Repeat the same installation process for the other side.

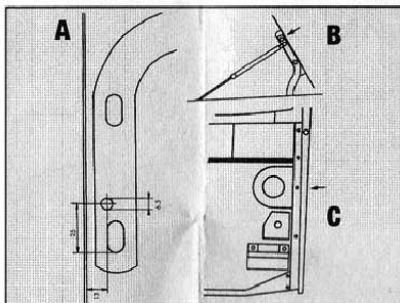

VW Mk3 Golf, Vento

- Please read full instructions before installation
- If the cylinder is under pressure, please do not open or heat up
- Lifting force will be lower in colder temperatures
- Always install the cylinder facing upwards

Included in Kit:

2 x Bonnet lifter
4 x right angled-joint & security clip
4 x M8 x 15mm ball pins
2 x Ballscrew
2 x M8 large washer
2 x M8 small washer

Tools Required

10mm ring spanner or 10mm socket spanner
13mm ring spanner or 13mm socket spanner

Fitting Instructions

1. Remove the front M8 bolts from the left hinge (A).
2. Fit the supplied M8 x 15mm bolts plus M8 washers.
3. Remove the third (from the front) chassi bolt (B).
4. In its place fit the ballpin, using the washer.
5. Cut out a V-shaped part from the rubber block that is glued to the bonnet (C).
6. Fit the joints to the bonnet lifter and remove the security clip.
7. Fit the bonnet lifter (with the cylinder facing upwards to the ballpin (these need to be fitted tightly).
8. Fit the security pin back to the joint, these are needed for the bonnet lifter to continue working.
9. Repeat the same installation process for the other side.

Attention:

Please follow the instructions closely in order to avoid any damage.

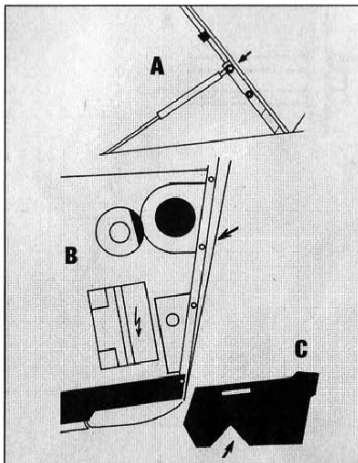

VW Polo 86c/Derby

- Please read full instructions before installation
- If the cylinder is under pressure, please do not open or heat up
- Lifting force will be lower in colder temperatures
- Always install the cylinder facing upwards

Included in Kit:

2 x Bonnet lifter
4 x right angled-joint & security clip
2 x M6 x 20mm (M8 x 15mm) ball pins
2 x Ballscrew
2 x M8 large washer
4 x M8 small washer
(numbers in brackets are for Polo Mk3)

Tools Required

10mm ring spanner or 10mm socket spanner
13mm ring spanner or 13mm socket spanner

Fitting Instructions

1. Remove the front M6 (M8) bolts from the left hinge (A).
2. Fit the supplied M6 x 20mm (M8 x 15mm) bolts plus M6 (M8) washers.
3. Remove the third (from the front) chassi bolt (B).
4. In its place fit the ballpin, using the washer.
5. Cut out the foam block that is glued to the bonnet (C).
6. Fit the joints to the bonnet lifter and remove the security clip.
7. Fit the bonnet lifter (with the cylinder facing upwards) to the ballpin (these need to be fitted tightly).
8. Fit the security pin back to the joint, these are needed for the bonnet lifter to continue working.
9. Repeat the same installation process for the other side.

Attention:

Please follow the instructions closely in order to avoid any damage.

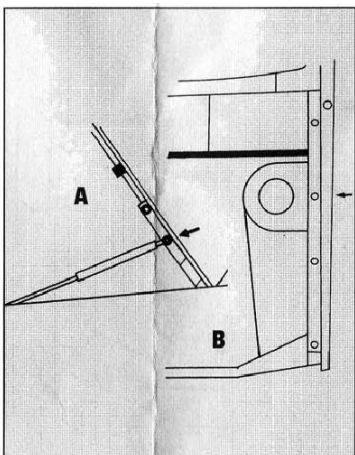

VW Polo 6N (not Mk2 Caddy)

- Please read full instructions before installation
- If the cylinder is under pressure, please do not open or heat up
- Lifting force will be lower in colder temperatures
- Always install the cylinder facing upwards

Included in Kit:

2 x Bonnet lifter
4 x right angled-joint & security clip
2 x M8 x 15mm ball pins
2 x Ballscrew
2 x M8 large washer
2 x M8 small washer

Tools Required

10mm ring spanner and 10mm socket spanner
13mm ring spanner or 13mm socket spanner
4mm Drill

Fitting Instructions

1. Remove the front M8 bolts from the left hinge (A).
2. Fit the supplied M8 x 15mm bolts plus M6 (M8) washers.
3. Remove the second (from the front) chassi bolt (B).
4. In its place fit the ballpin, using the washer.
5. Remove the front bolt from the right hinge and fit the ballpin plus washer.
6. Drill a 4mm hole into the wing for the fitting of the bonnet lifter, with a 400mm distance to the middle of the hinge.
7. Apply an anti rust/corrosion to the drilled hole and fit the ballpin using the washer.
8. Fit the joints to the bonnet lifter and remove the security clip.
9. Fit the bonnet lifter (with the cylinder facing upwards to the ballpin (these need to be fitted tightly).
10. Fit the security pin back to the joint, these are needed for the bonnet lifter to continue working.
11. Repeat the same installation process for the other side.

